



May 25, 2010

TO: AFFECTED DEALERS

**SUBJECT: SERVICE BULLETIN S10RX CHARGE AIR COOLER TUBE
SUPPORT BRACKET**

MODELS AFFECTED: 2010-2011 ALL AMERICAN (D3RE)

The charge air cooler tube support bracket on the subject units may fail. The original charge air cooler tube support bracket must be replaced with a new bracket according to Service Bulletin S10RX. Copy attached.

Time allowed to remove and replace the support bracket is 0.5hrs (30 minutes) per bus.

Parts for Service Bulletin S10RX are available in limited quantities and must be ordered through Blue Bird Service Parts.

A printout of your buses affected by Service Bulletin S10RX is attached.

Service Bulletin S10RX is being mailed directly to owners. Owners are being advised to contact their dealer for assistance, if needed.

Service Bulletin S10RX ends one (1) year from date of issue. Claims for repairs performed after the end date cannot be submitted to Blue Bird.

Questions regarding Service Bulletin S10RX should be directed to your Blue Bird Service Representative.

Sincerely,

Bill Coleman
Engineering Services
Blue Bird Corporation
478-822-2242
bill.coleman@blue-bird.com



BLUE BIRD

May 25, 2010

Dear Blue Bird Owner,

You will find enclosed a copy of Service Bulletin S10RX regarding the charge air cooler tube support bracket on your 2010-2011 model year Blue Bird All American rear engine model bus(es) identified by body number on the enclosed cover sheet.

The charge air cooler tube support bracket on the subject units may fail. The original charge air cooler tube bracket must be replaced with a new bracket according to Service Bulletin S10RX. Copy attached.

Time allowed to remove and replace the bracket is 0.5hrs (30 minutes) per bus.

Replacement parts must be ordered through your Blue Bird dealer.

You may contact your Blue Bird dealer to arrange to have this service bulletin performed. Or, if you prefer, you may perform this service bulletin yourself or have a qualified repair facility convenient to you perform it. A qualified technician should perform this procedure.

Service Bulletin S10RX ends one (1) year from date of issue.

Should you have any questions concerning this bulletin, please contact your Blue Bird dealer.

Sincerely,

Bill Coleman
Engineering Services
Blue Bird Corporation
478-822-2242
bill.coleman@blue-bird.com

BLUE BIRD BODY COMPANY

P.O. Box 937 – 402 Blue Bird Blvd – Fort Valley, Georgia – (478) 825-2021



Models Affected: 2010-2011 All American (D3RE) with Cummins ISC Engines

ISSUE

Charge air cooler tube support bracket may fail.

CORRECTIVE ACTION

Replace original charge air cooler tube support bracket with new bracket.

PROCEDURE

WARNING: Always follow all Federal, State, Local and Shop safety standards and use proper safety equipment when performing these procedures.

1. Park the bus on a level surface, apply parking brakes, turn off engine and remove keys. Chock wheels.
2. Remove existing charged air cooling tube support bracket, part number 00127738, and the related clamps per diagram below and discard. Retain fasteners to engine for use with new bracket.

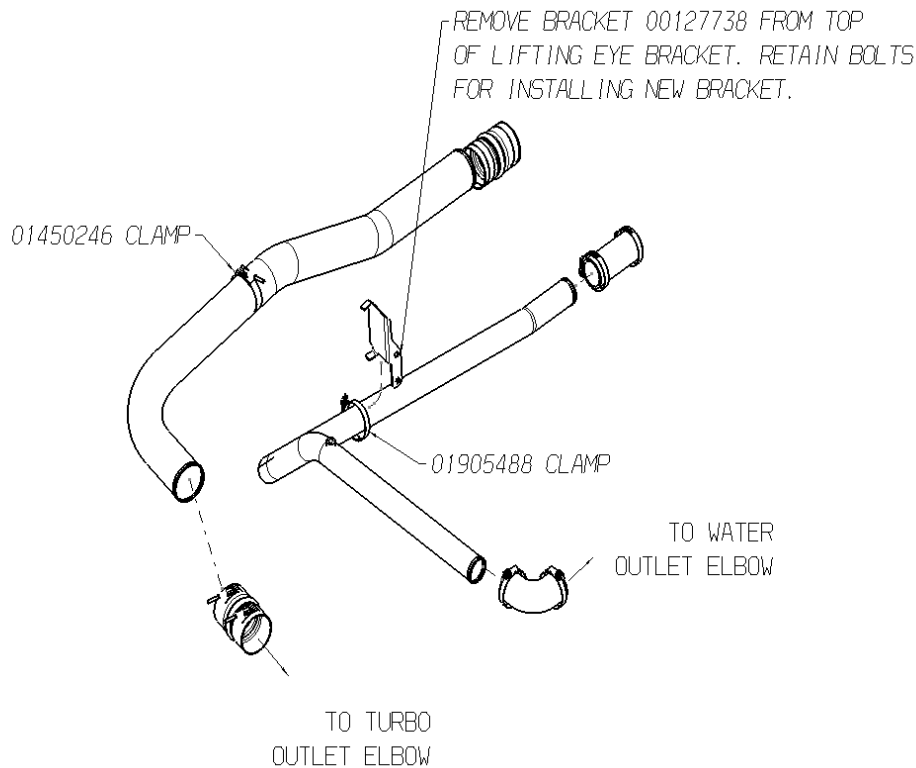

S I O R X
S E R V I C E B U L L E T I N



3. Install new charged air cooling tube support bracket, part number 10014751, and the related clamping components per diagram below.

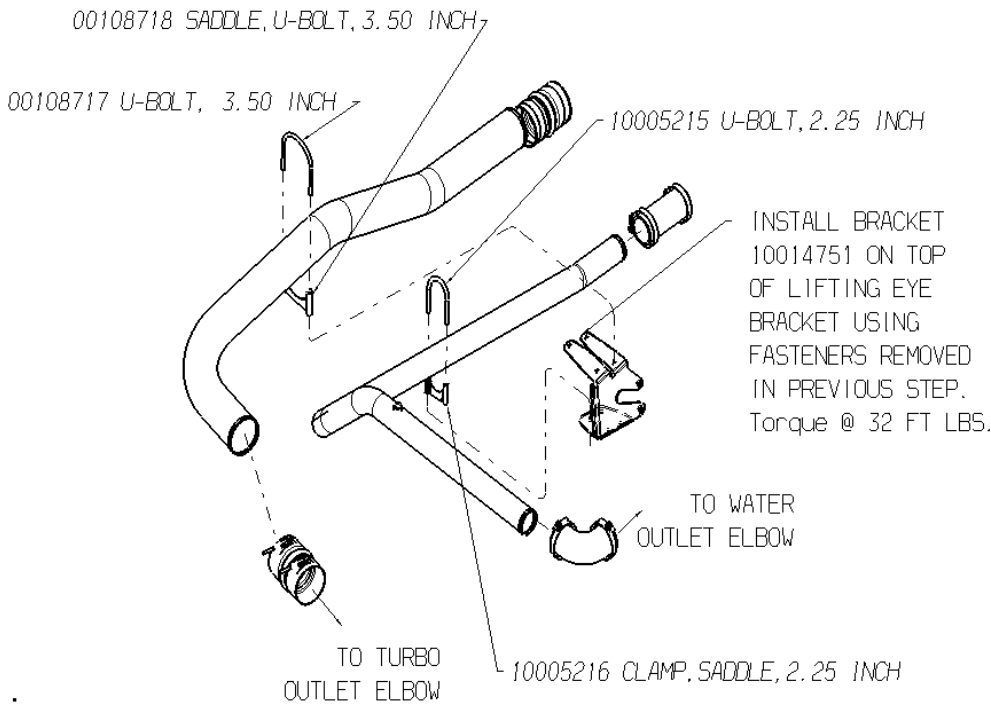

4. Remove wheel chocks and return unit to service.

PARTS:

Part No.	Description	Qty
10014751	Bracket, Supt, CAC, Tube, Cumn ISC, D3RE	1
10005215	Clamp, U-bolt, 2.25 in	1
10005216	Clamp, Saddle, 2.25 in	1
00108717	U-bolt, Exhaust, 3.5in, Pipe Clamp	1
00108718	Saddle, U-bolt, 3.5in Exhaust Pipe	1