



## BBCV POWER STEERING RESERVOIR CONVERSION

# UPDATE

Models Affected: BBCV units manufactured from 12/17/2007 thru 06/22/2010  
and equipped with frame mounted power steering reservoir.

A Power Steering Reservoir Conversion Kit is available for Vision (BBCV) units built with the frame mounted steel power steering reservoir. Use the following procedures to convert the power steering reservoir from the original steel type reservoir to the new composite type power steering reservoir.

**WARNING:** Always follow all Federal, State, Local and Shop safety standards and use proper safety equipment when performing these procedures.

1. Park the bus on a level surface, apply parking brakes, turn off engine, remove keys and chock wheels.
2. Follow the step by step instructions and diagrams provided to install the power steering reservoir conversion kit.

### Power Steering Reservoir Conversion

- A. Disconnect the 1/2" pressure hose from the steel power steering reservoir (PSR) and drain the fluid.
- B. Disconnect the 3/4" hose from the steel PSR and drain the fluid.
- C. Once all of the fluid is drained, remove the steel PSR by removing the four sets of 3/8" hardware holding it to the frame rail. Retain hardware for later installation of the composite PSR.
- D. Referring to illustration #1, install the composite PSR mounting bracket, item #1, with the same hardware used to mount the steel PSR. Torque hardware to 29-33 Ft-Lbs as specified.
- E. While still referring to illustration #1, mount the composite PSR to its mounting bracket with items #6, #7 and #8. Torque to 20-23 Ft-Lbs as specified. **Caution: This torque is not the normal torque for this hardware. Since this hardware is holding a composite part, the normal torque with this hardware could damage the tank.**
- F. Trim the 3/4" hose to length and install onto the 3/4" supply port of the PSR. Install hose clamp 01025857, (item #4) and tighten to secure hose. Clamp or tie wrap the 3/4" hose so it does not rub on any chassis components or the steering shaft. Split loom may be used as an added protection against rubbing.

S U 1 1 0 2

S E R V I C E U P D A T E

- G. Referring to illustration #2 or #3, install elbow, (item #2) and 1/2" hose, (item #5) to the return line port of the PSR. Depending upon the steering configuration of your bus, you may be able to cut a 2-1/2" piece off of the 1/2" hose to use at the bottom of the reservoir for item #5. If this will not work in your scenario, obtain a piece of 1/2" hydraulic hose. Install hose clamp 02027571, (item #3) and tighten to secure hose. Clamp or tie wrap the 1/2" hose so it does not rub on any chassis components or the steering shaft. Split loom may be used as an added protection against rubbing.
- H. Open the cap of the new composite PSR and fill with Dexron ATF fluid. Fill new reservoir to cold mark. Do not fill higher than the top most cold mark. Refer to Illustration #1.
- I. Start the vehicle and prime the steering system in accordance to the procedures stated in the service manual. Take note of the drop in fluid in the tank. Once the system has fully primed and has purged itself of air, refill the tank as shown on Illustration #1. Do not overfill the new PSR. If too much fluid is added to this tank, the fluid will run out of the breather cap when the fluid gets hot.
- J. Return bus to service.

**Illustration #1**

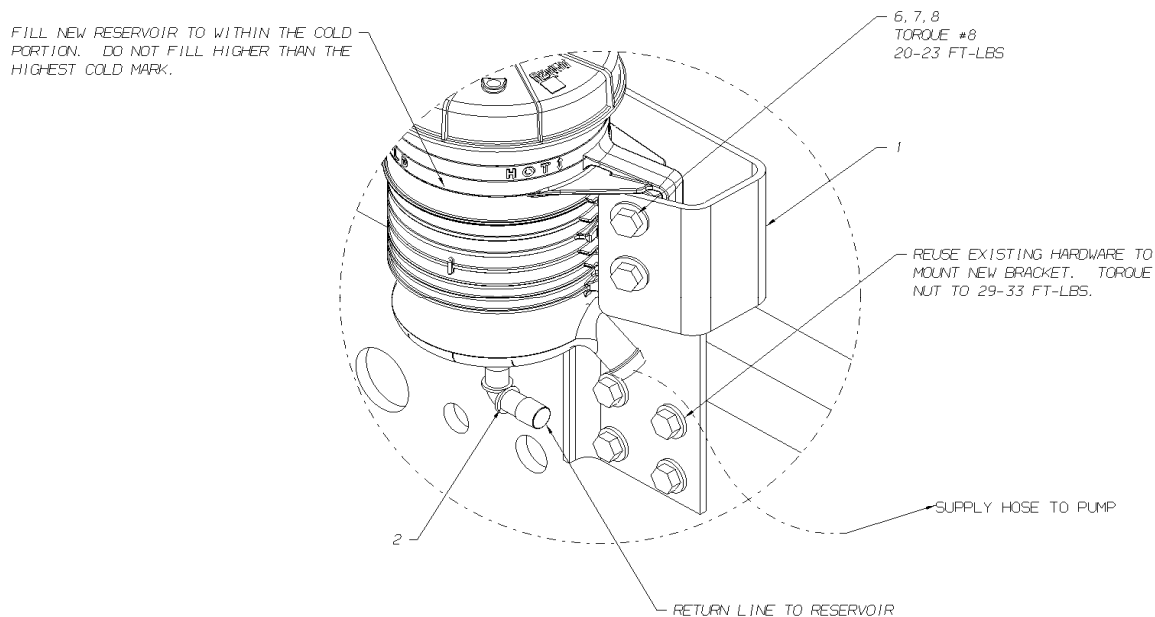
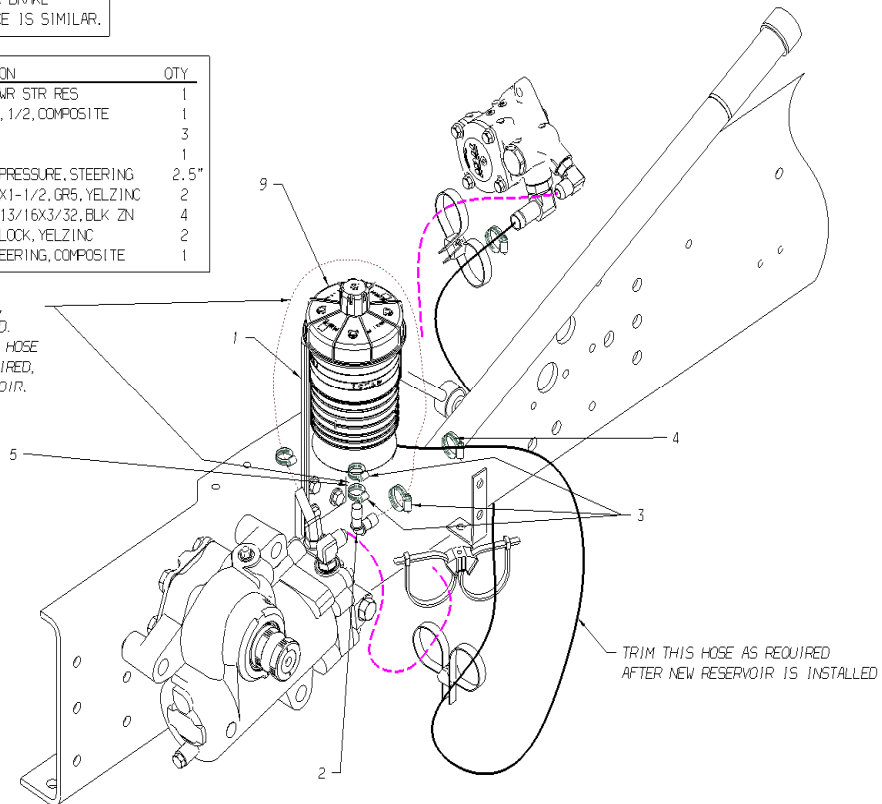

**Illustration #2**

TYPICAL POWER STEERING RESERVOIR CHANGE  
ON CAT OR CUMMINS ENGINES. AIR BRAKE  
INSTALLATION IS SHOWN. HYD BRAKE IS SIMILAR.

KEY	P/N	DESCRIPTION	QTY
1	10009560	BRACKET, MOUNTING, PWR STR RES	1
2	10009940	ELBOW, 90 DEG, UNION, 1/2, COMPOSITE	1
3	02027571	CLAMP, HOSE, 6203	3
4	01025857	CLAMP, HOSE, SIZE 8	1
5	01341692	HOSE, 1/2 INCH, LOW PRESSURE, STEERING	2.5*
6	02050839	BOLT, HEX HD, 3/8-16X1-1/2, GR5, YELZINC	2
7	01107085	WASHER, FLAT, 13/32X13/16X3/32, BLK ZN	4
8	00826297	NUT, HEX HD, 3/8-16 LOCK, YELZINC	2
9	10005156	RESERVOIR, POWER STEERING, COMPOSITE	1

DEPENDING UPON THE INSTALLATION,  
THIS HOSE MAY NEED TO BE TRIMMED.  
IF SO, USE THE EXCESS FROM THIS HOSE  
FOR THE 2.5" PIECE OF HOSE REQUIRED,  
#5, ON THE BOTTOM ON THE RESERVOIR.



**Illustration #3**

TYPICAL POWER STEERING RESERVOIR CHANGE ON PROPANE ENGINE. AIR BRAKE INSTALLATION IS SHOWN. HYD BRAKE IS SIMILAR.

KEY	P/N	DESCRIPTION	QTY
1	10009560	BRACKET, MOUNTING, PWR STR RES	1
2	10009940	ELBOW, 90 DEG, UNION, 1/2, COMPOSITE	1
3	02027571	CLAMP, HOSE, 6203	3
4	01025857	CLAMP, HOSE, SIZE 8	1
5	01341692	HOSE, 1/2 INCH, LOW PRESSURE, STEERING	2,5"
6	02050839	BOLT, HEX HD, 3/8-16X1-1/2, GR5, YEL ZINC	2
7	01107085	WASHER, FLAT, 13/32X13/16X3/32, BLK ZN	4
8	00826297	NUT, HEX HD, 3/8-16 LOCK, YEL ZINC	2
9	10005156	RESERVOIR, POWER STEERING, COMPOSITE	1

