



Fuel Tank Overfill Venting *UPDATE*

Model Affected: 2008-2011 Vision (BBCV), All American (A3FE, A3RE)
2010-2011 All American (D3FE, D3RE)

An overfilled tank may allow diesel fuel to seep out of the vent during warm weather conditions. To prevent this condition, make sure that the warning label on the fuel door that states “Do Not Fill More Than 95% of Liquid Capacity” is being followed and if needed, install the current production fuel tank vent (10013053). Also, check that the vent hose is clear of any obstructions and routed so as not to be pinched/kinked.

PROCEDURE

WARNING: Always follow all Federal, State, Local and Shop safety standards and use proper safety equipment when performing these procedures. Thoroughly read and understand all instructions before performing this procedure.

1. Park the bus on a level surface, apply parking brakes, turn off engine and remove keys. Chock wheels.
2. Follow standard replacement instructions to replace fuel tank vent with 10013053.

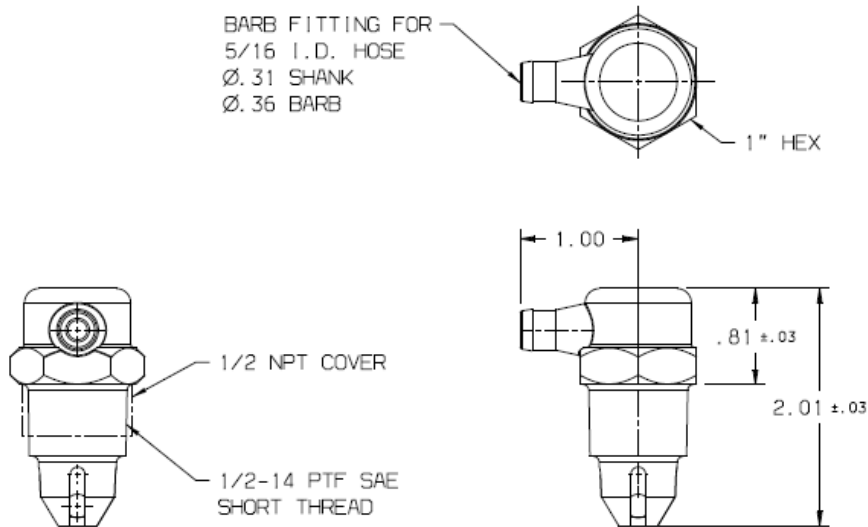

3. Remove wheel chocks and return bus to service.

Parts List

<u>Part Number</u>	<u>Description</u>	<u>Qty</u>
10013053	Vent, Fuel Tank, GT Tech 2113	1 (as needed)